



T Machinery a.s.

MFK 400.SNO

MFK400.SNO

MFK 400.SNO



JB

MFK400.SNO

MFK 400.SNO

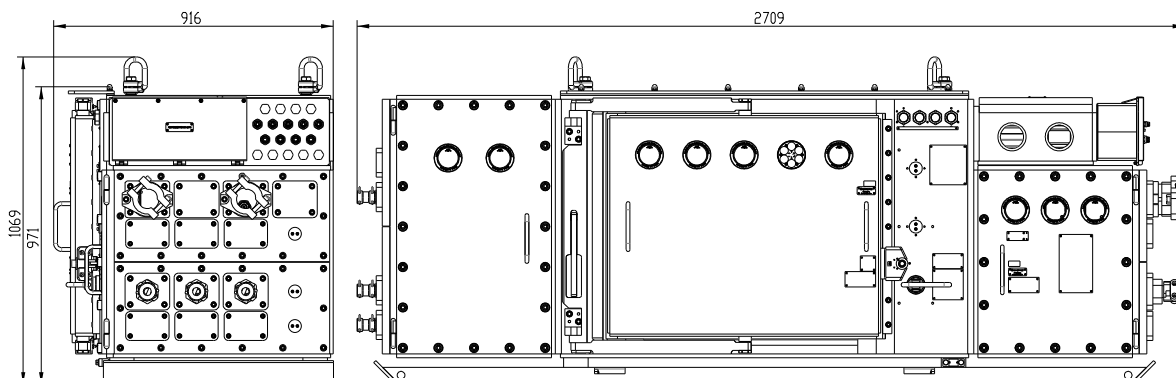



MFK 400.SNO

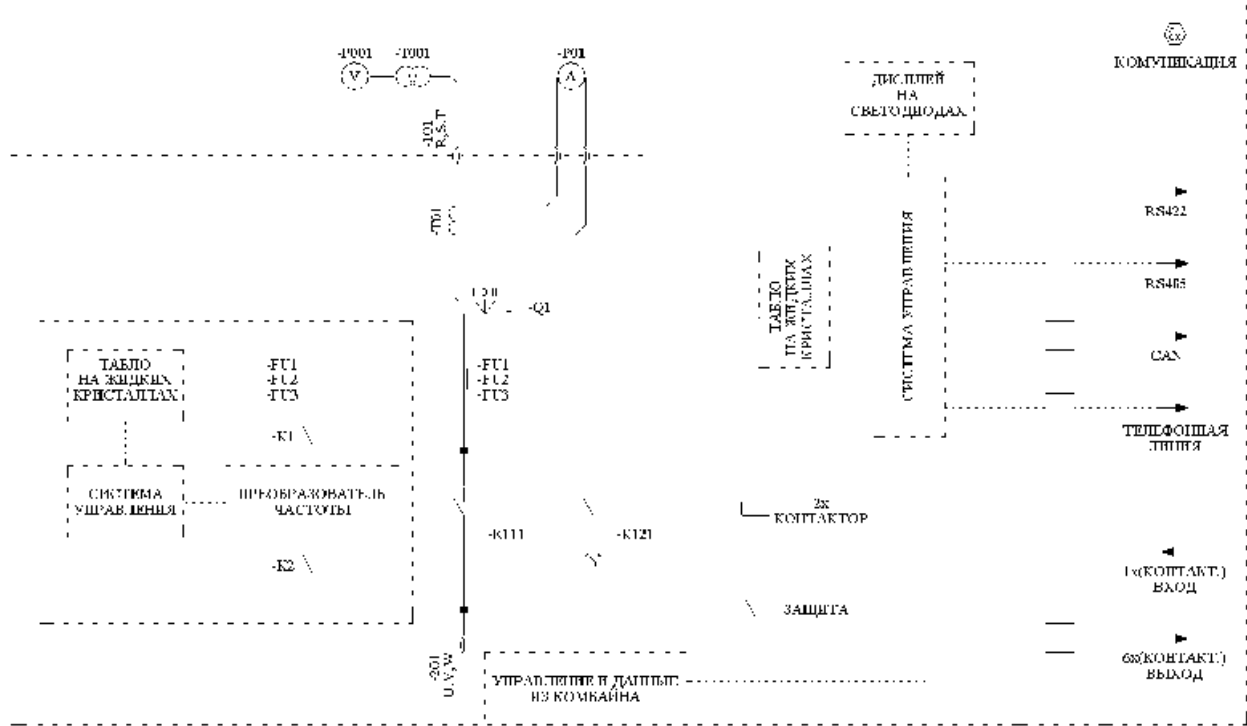

	2 x 50 (500) 2 x 65 (660)	
()	3 AC 500 / 660	
	50	
	5 – 120	
	150	A
	200	A
		-
	DN20	-
()	30	
	4	/ .
()	5 – 25	°C
()	2709 x 971 x 916	
	2400	
	0 +40	°C
	IP 54	-